

RTRS-2-TMWW

curtis

CORIENTE V2

- FINISHED IN WHITE BAKED ENAMEL INTERIOR & EXTERIOR.
- 1 1/2" STAINLESS STEEL RAMPED FLOOR.
- 4 FULL LENGTH, SOLID HINGED DOORS.
- STAINLESS STEEL CART GUIDE BUMPERS.
- DIGITAL THERMOMETER.
- TOP-MOUNTED, SELF-CONTAINED, 1/2 H.P., AIR-COOLED REFRIGERATION SYSTEM, R-404A, 115/1/60.

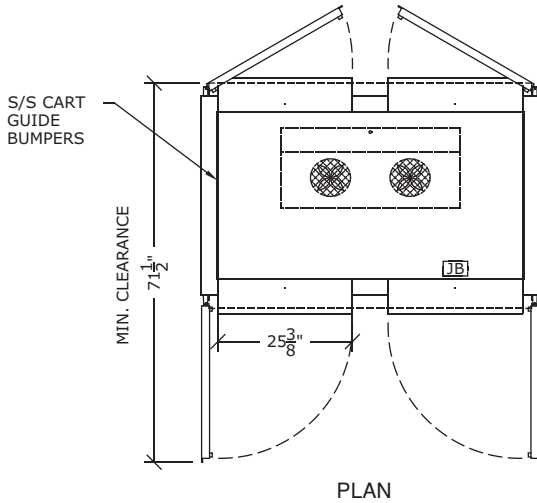

LEGEND

JB - JUNCTION BOX ON TOP OF REACH-IN

NOTES:

* DRAIN CONNECTION BY OTHERS

RAMP DETAIL

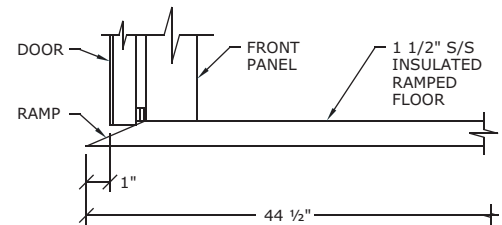

NOTE: RAMP EXTENDS 1" OUT FROM THE FRONT OF EACH DOOR. TOTAL FLOOR DEPTH IS 44 1/2".

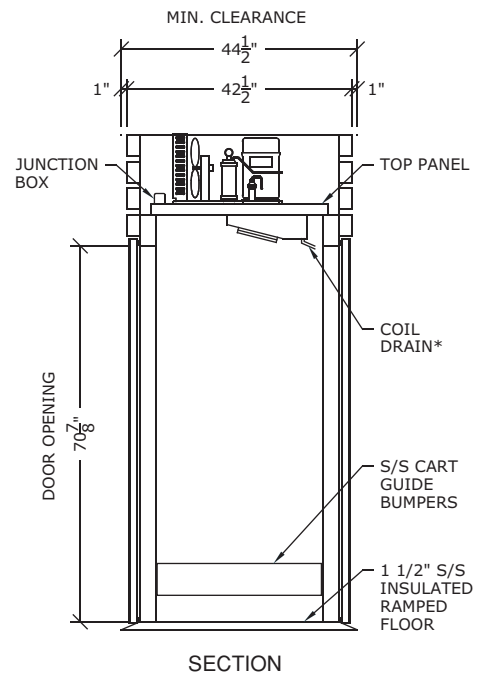
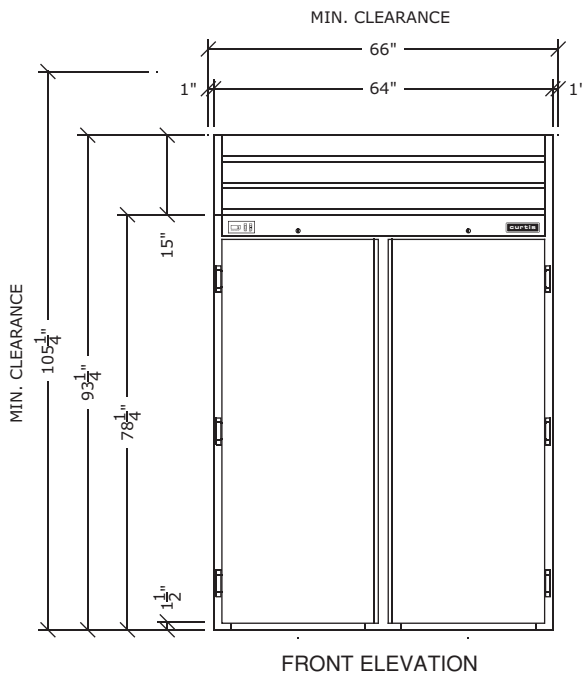

ROLL-THRU REFRIGERATOR (4°C/39°F)

PDS-RTRS-2-TM-10/06

CAPACITY		HEIGHT		WIDTH		DEPTH		DOORS		SHELVES	ELECTRICAL			WEIGHT		SHPG. VOL.
C.F.	LTR.	IN.	CM.	IN.	CM.	IN.	CM.	FULL STD.	HALF OPT.		H.P.	VOLT.	AMP.	LB.	KG.	C.F.
94	2663	93 1/4	237	64	163	42 1/2	108	4	N/A	N/A	1/2	115/1/60	15.1	800	1050	100