

# RIFS-3-TMWW

# curtis

## CORIENTE V2

- FINISHED IN WHITE BAKED ENAMEL INTERIOR & EXTERIOR.
- 1 1/2" STAINLESS STEEL RAMPED FLOOR.
- 3 FULL LENGTH, SOLID HINGED DOORS.
- STAINLESS STEEL CART GUIDE BUMPERS.
- DIGITAL THERMOMETER.
- TOP-MOUNTED, SELF-CONTAINED, 1 1/2 H.P., AIR-COOLED REFRIGERATION SYSTEM, R-404A, 230/1/60.

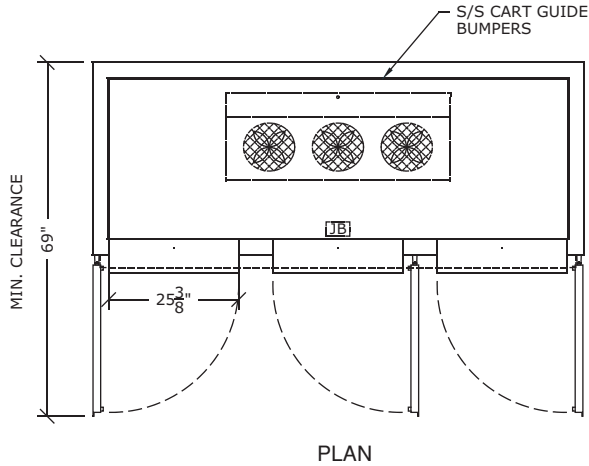

LEGEND	NOTES:
<b>JB</b> - JUNCTION BOX ON TOP OF REACH-IN	* DRAIN CONNECTION BY OTHERS

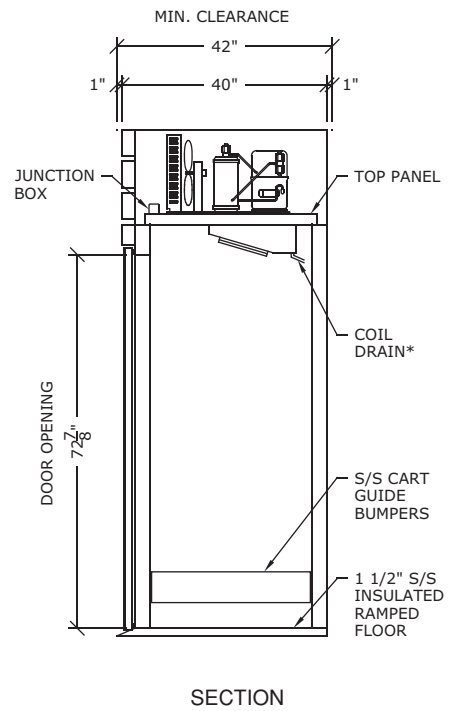
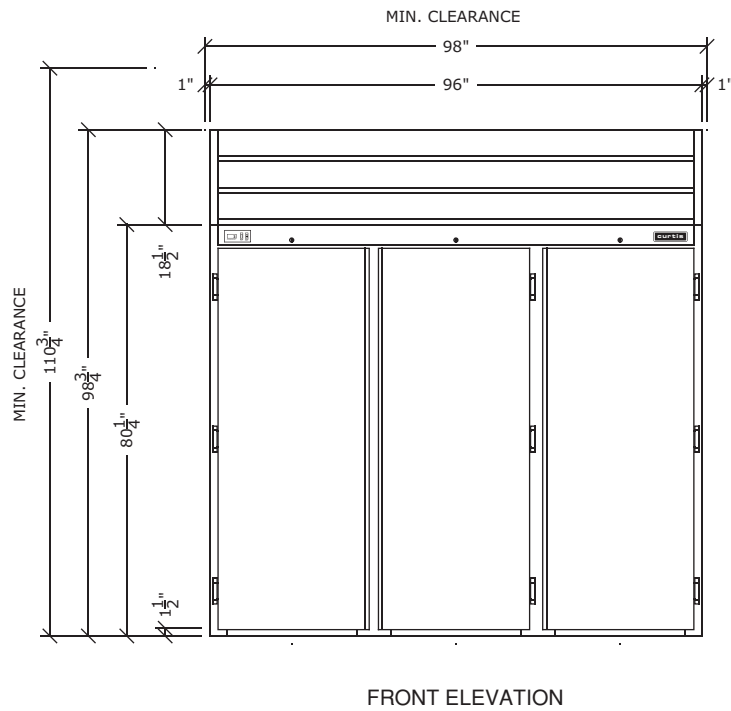
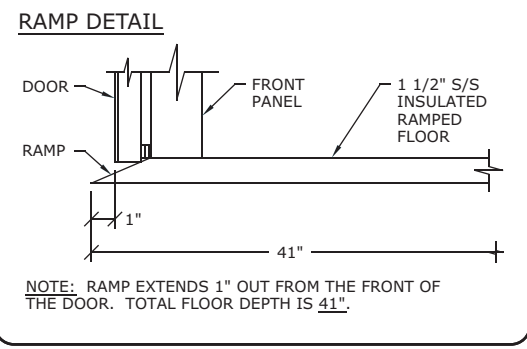

ROLL-IN FREEZER (-18°C/0°F)

PDS-RIFS-3-TM-10/06

CAPACITY		HEIGHT		WIDTH		DEPTH		DOORS		SHELVES	ELECTRICAL					WEIGHT		SHPG. VOL.
C.F.	LTR.	IN.	CM.	IN.	CM.	IN.	CM.	FULL STD.	HALF OPT.		H.P.	VOLT.		AMP.		LB.	KG.	C.F.
										FREEZER	FREEZER	CABINET	FREEZER	CABINET				
139	3938	98 3/4	251	96	244	40	102	3	N/A	N/A	1 1/2	230/1/60	115/1/60	15.4	2.8	1200	1400	150