

HGFS-1-TMWW

curtis

CORIENTE V2

- FINISHED IN WHITE BAKED ENAMEL INTERIOR & EXTERIOR.
- STAINLESS STEEL FLOOR.
- 1 FULL LENGTH, GLASS HINGED DOOR.
- 3 EPOXY COATED WIRE SHELVES.
- DIGITAL THERMOMETER.
- 1 3/4" ADJUSTABLE LEGS.
- ELECTRIC CONDENSATE EVAPORATOR PAN.
- TOP-MOUNTED, SELF-CONTAINED, 3/4 H.P., AIR-COOLED REFRIGERATION SYSTEM, R-404A, 230/1/60.

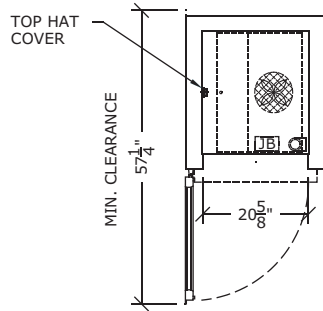

PLAN

LEGEND	
	- JUNCTION BOX ON TOP OF REACH-IN
	- DRAIN LOCATION UNDER REACH-IN
	- INTERIOR FLUORESCENT LIGHT FIXTURE

NOTES:
* LEGS NOT FULLY EXTENDED, ALLOW MIN. 1 3/4" (44mm) ABOVE UNIT
** 115/1/60 AMP. LOAD INCLUDES 1.0 AMPS FOR EVAPORATOR PAN

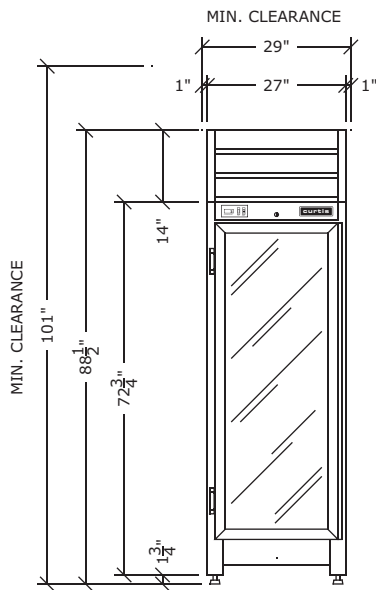

FRONT ELEVATION

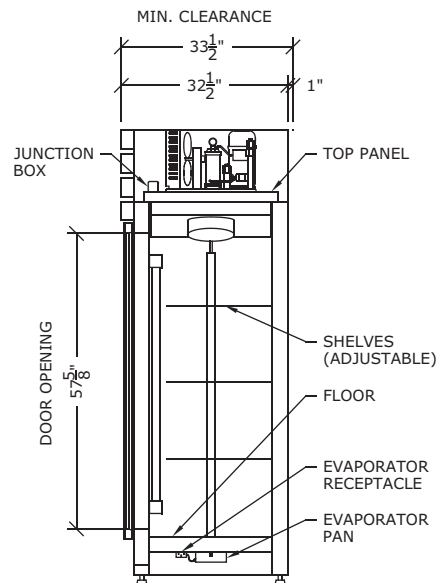

SECTION

HINGED GLASS FREEZER (-18°C/0°F)

PDS-HGFS-1-TM-10/06

CAPACITY		HEIGHT *		WIDTH		DEPTH		DOORS		SHELVES	ELECTRICAL **					WEIGHT		SHPG. VOL.
C.F.	LTR.	IN.	CM.	IN.	CM.	IN.	CM.	FULL STD.	HALF OPT.		H.P.	VOLT.		AMP.		LB.	KG.	C.F.
												FREEZER	FREEZER	CABINET	FREEZER			
21	589	88 1/2	223	27	69	32 1/2	83	1	N/A	3	3/4	230/1/60	115/1/60	9.3	3.3	450	204	47